

EBERSPÄECHER VECTURE

# BATTERY MANAGEMENT SYSTEMS

High Voltage Distributed Products

Since 2001, Eberspaecher Vecture has been designing and manufacturing mission critical battery management systems (BMS), fuel gauging and complementary power electronics. The Company offers its international partners a full range of electronics manufacturing services (EMS) including product design, rapid prototyping, supply chain management, manufacturing and 100% functional testing.

## Product Line

- Custom, Off-the-Shelf and Build-to-Print
- Integrated - 12 V to 80 V
- Distributed - 80 V to 1000 V
- Lithium chargers, DC-DC converters
- Cell Supervising Circuits
- Supports different battery chemistries



## Product Features

- Passive cell balancing
- Monitor/protect for over/under conditions (voltage, current, temperature)
- Fuel Gauging
- Detection - State-of-Charge (SOC), State-of-Health (SOH)
- Communication - SMBus, I2C, SPI, CAN, BLE, Wifi



## Distributed System Overview

Eberspaecher Vecture's distributed system consists of 1 Battery System Manager (BSM) and depending on the application up to 20 Battery Cell Managers (BCM) that manage and monitor cell performance. Optional voltage transducers are also available. This modular and scalable system is ideal for mobility, energy storage, UPS, industrial and other high voltage applications.

### BSM - V04282

- Manages contactors and pre-charging
- Monitors voltages of the battery pack
- Communicates with outside system via CAN

### BCM - V04288

- 4-16S
- Measures temperature and voltages of the cells
- Communicates with the BSM via data link

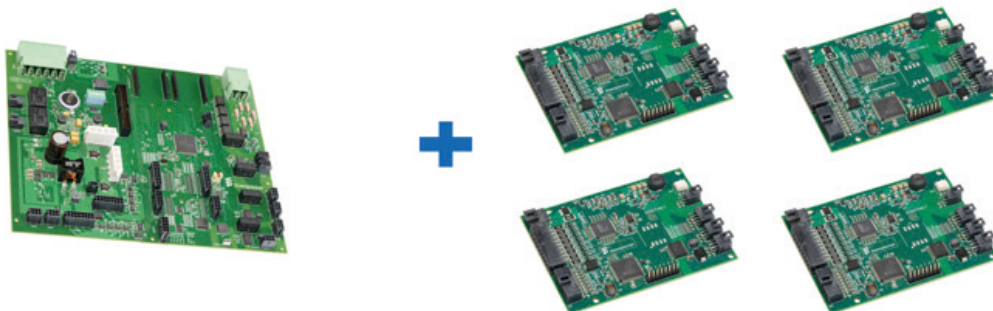

# V04282 – HIGH VOLTAGE DISTRIBUTED BMS

The Battery String/System Manager (BSM) for a distributed system is designed to work together with the Battery Cell Manager (V04288) and the Voltage Transducer (V07036) to complete the entire system. It monitors up to 20, V04288 boards while monitoring string voltage through the V07036.

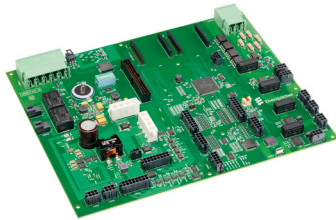

## MARKET SEGMENTS:

- Energy Storage
- Off-road Mobility
- Industrial Applications
- UPS
- Renewable Power

## TECHNICAL DATA:

Supply Voltage from Battery	12V ± 5 %
Operating Temperature	(-40)°C- 85°C
Ground fault controlled Battery System Voltage	100V-1000V
Idle or Sleep consumption	10mA Max, no Host (CAN) connected, no contactors driver
Active consumption	150mA-250mA, Host (CAN) connected, no contactor driver, no analog & digital outputs/inputs
High Range Discharge Current-OCD	≤625A and determined by external current transducer and contactors
Supported CAN comm type	CANOpen protocol
Supported CAN speed 1	For communication with Cell Manager Modules: 500 kbps
Temperature sensing Inputs	3 optional ; 10K NTC thermistors ; -45 to + 85C
HV Voltage sensing input	3: 1000Vdc - Max with external transducer
Dimensions	255mm (L) x 205mm (W) x 30mm (H)

## PRODUCT FEATURES:

SOC Display	Optional LED indicators
Watchdog	Stand alone on board window-based Watchdog IC
Usability	On board data logging

Three independent isolated CAN interfaces all 3 CANs are 1000Vdc isolated. Each CAN has two parallel connectors.

## OTHER FEATURES:

Can be powered by an external power supply
The controller has a Ground Fault Interruption (GFI) built in
There is an interface to gather current sensing information via LEM, shunt, or CAN based on the specific system implementation

# V04288 – HIGH VOLTAGE DISTRIBUTED BMS

The Battery Cell Manager (BCM) manages and monitors cell performance for a distributed system and works together with the Battery String/System Manager (V04282) and the Voltage Transducer (V07036) to complete the system.

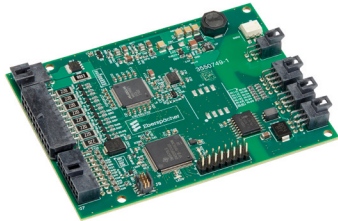

## MARKET SEGMENTS:

- Energy Storage
- Off-road Mobility
- Industrial Applications
- UPS
- Renewable Power

## TECHNICAL DATA:

Power Supply (B+ to B- or P+ to P-)	12.5V- 67V
Operating Temperature	(-40)°C- 50°C
Accuracy of voltage measurement	±0.1%, ±3mV Max
Active consumption (@ VCELL = 3.65V from B+)	10mA
Active consumption (from External Power Supply @ 12 Vdc)	30mA Max
Shut down consumption (from B+)	500uA Max
Cell balance topology	Passive
Cell balance activation (during charging)	≥3.45V
# of temp sensors (NTCs)	External sensors up to 8 & on board PCB TEMP sensor
Accuracy of temperature measurement – Stability	±1°C
Supported CAN comm type	Open
Safety interlock	100V, 3.5A; 40mV voltage drop at 0.5A
Dimensions	105.0mm (L) x 80.0mm (W) x 15.0mm (H)

## PRODUCT FEATURES:

Usability	16 MBytes of on-board SPI Serial Flash memory for event logging
State-of-charge (SoC) measurement	Yes, this function is done on V04282 controller board
State-of-health (SoH) measurement	Yes, this function is done on V04282 controller board
Standalone Window-Watchdog Timer as well as optional hydrogen sensor	

## OTHER FEATURES:

Number of cells	4-16S
Optional hydrogen sensor available	
BCM communicates to the Battery System Manager via isolated CAN interface	

# V07036 – HIGH VOLTAGE DISTRIBUTED BMS

The Voltage Transducer works together with the Battery String/System Manager (V04282) and the Battery Cell Manager (V04288) to complete a distributed system. V07036 provides string voltage data to V04282.

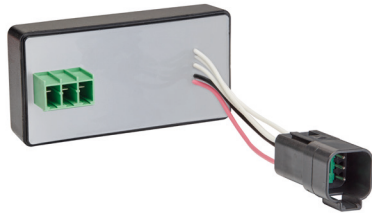

## MARKET SEGMENTS:

- Energy Storage
- Off-road Mobility
- Industrial Applications
- UPS
- Renewable Power

## TECHNICAL DATA:

Power Supply	8V-24V
Range of high voltage input measurement	0V-1000V
Operation temperature	(-40)°C-85°C
Power Supply	8V-24V
Quiescent Current	≤0.7mA
Dimensions	100mm (L) x 50mm (W) x 37mm (H)

## PRODUCT FEATURES:

Power Supply Current (@12V Supply)	5mA-30mA (5V Power supply configuration is available upon request)
Output Ratio Error	0.01 with a Voltage measurement accuracy of ±1%

## OTHER FEATURES:

Variants: V0703600	Voltage input 0-500V; V_out: 2.9V; Supply Voltage: 8-24V (Other Transfer ratios are available upon request)
Variants: V0703601	Voltage Input: 0-1000V, V_out: 2.9V; Supply Voltage: 8-24V (Other Transfer ratios are available upon request)

# BLOCK DIAGRAM – 1,000 V SYSTEM

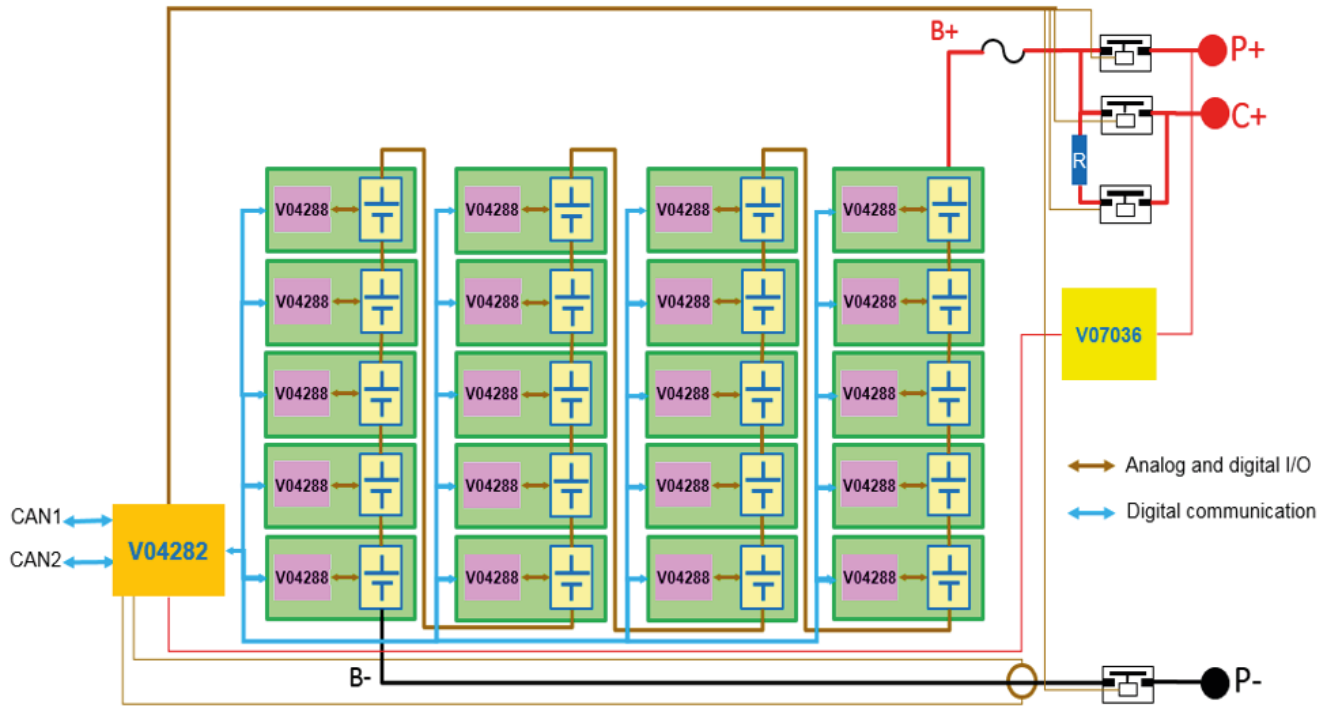

EBERSPAECHER VECTURE INC.  
8900 KEELE ST. UNIT 3  
CONCORD, ON L4K 2N2 / CANADA

PHONE: 905-761-0331  
FAX: 905-761-0334  
INFO-VECTURE@EBERSPAECHER.COM  
WWW.EBERSPAECHER-VECTURE.COM